

Safari

ORIGAMI



Lionel Albertino

Verlag Die Blechschachtel

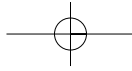

SOMMAIRE

Histoire du safari..... page 6
 Avant propos..... page 7
 Explications des symboles..... page 9
 Plis de bases..... page 12
 Modèles..... page 14
 Table des proportions..... page 152
 Quelques conseils..... page 153
 Le Wet folding..... page 155

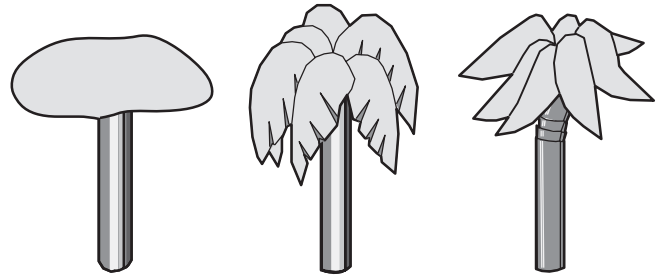

ARBRES
Page 14 à 18

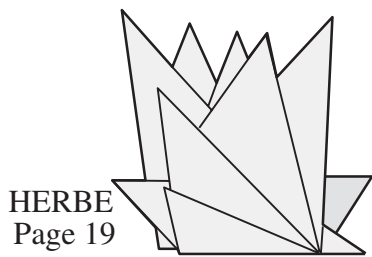

HERBE
Page 19

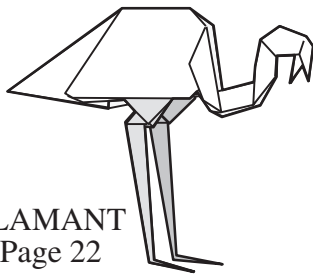

FLAMANT
Page 22

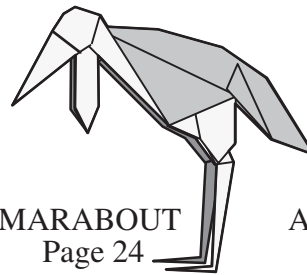

MARABOUT
Page 24

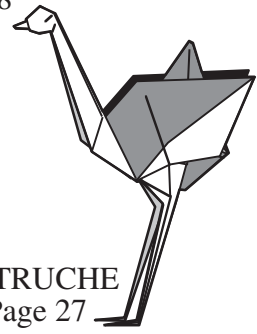

AUTRUCHE
Page 27



MARTIN-
PECHEUR
Page 31

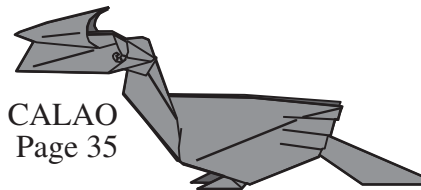

CALAO
Page 35

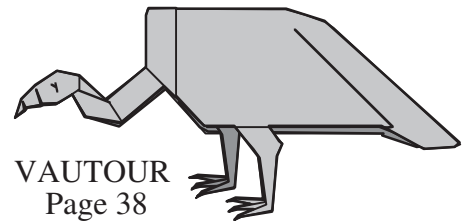

VAUTOUR
Page 38



GAZELLE
Page 42

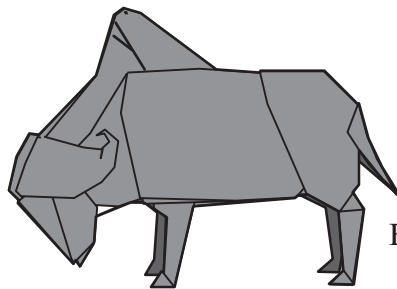

BUFFLE
Page 47



ZEBRE
Page 50

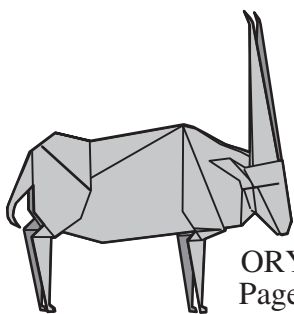

ORYX
Page 54



GENERUK
Page 59

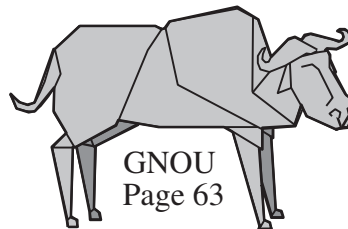

GNOU
Page 63

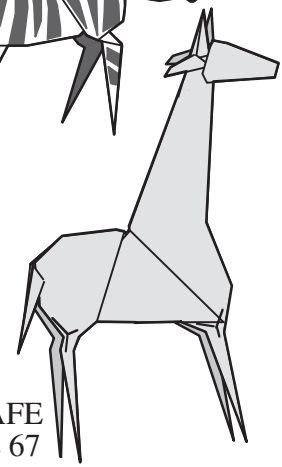

GIRAFE
Page 67

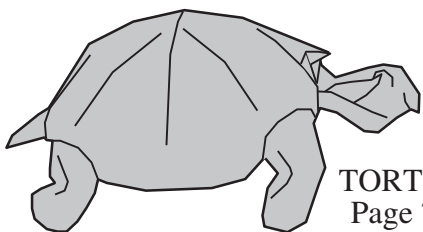

TORTUE
Page 71

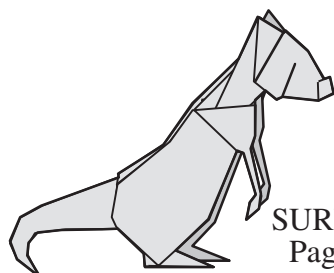

SURICAT
Page 76



GERBOISE
Page 79

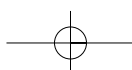

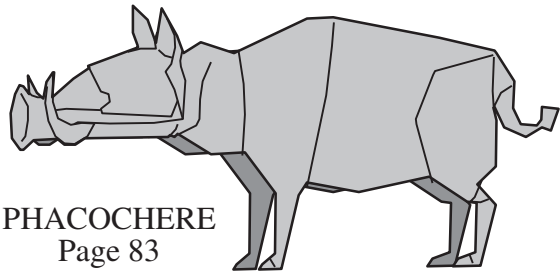
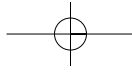

PHACOCHERE
Page 83

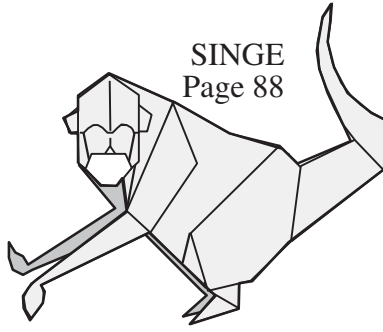

SINGE
Page 88

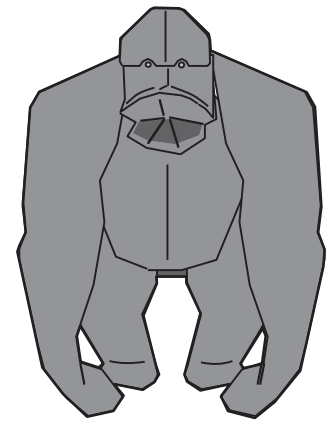

GORILLE
Page 92

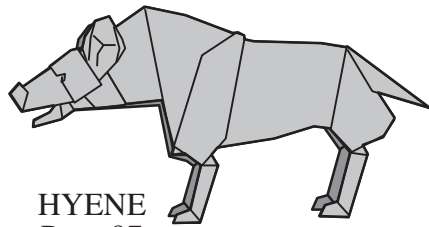

HYENE
Page 97

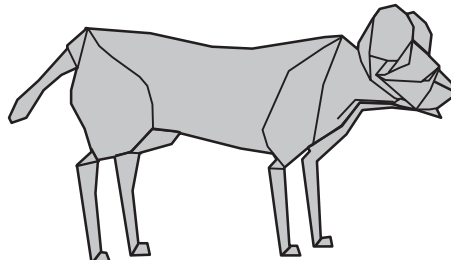

LYCAON
Page 103

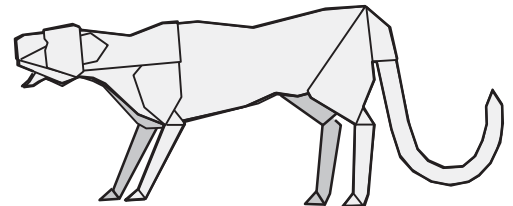

GUEPARD
Page 108

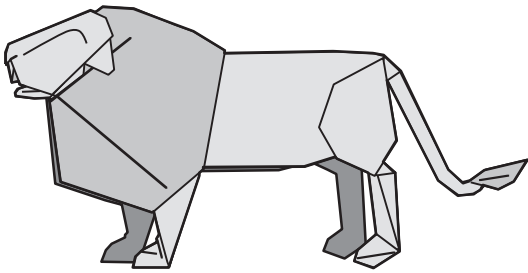

LION
Page 115

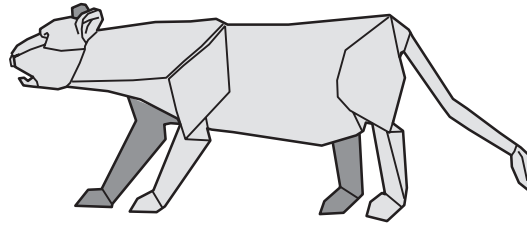

LIONNE
Page 122

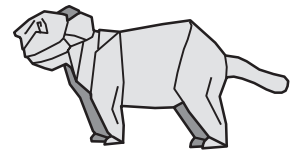

LIONCEAU
Page 125

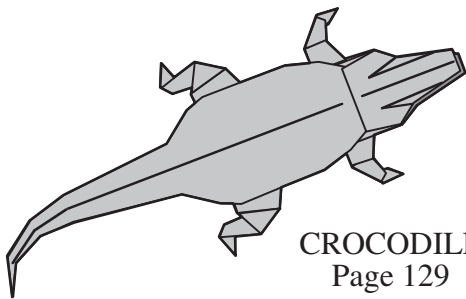

CROCODILE
Page 129

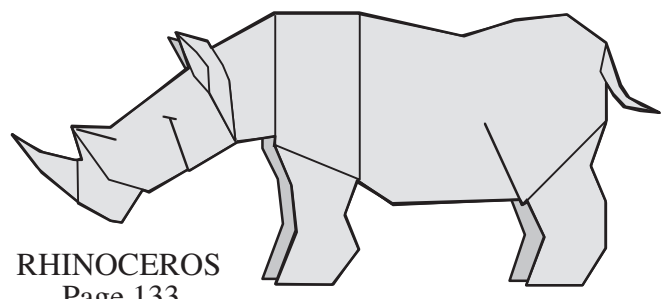

RHINOCEROS
Page 133

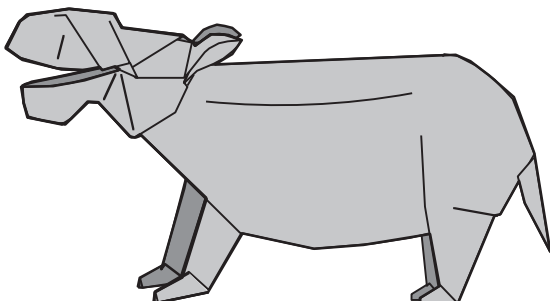

HIPPOPOTAME
Page 139

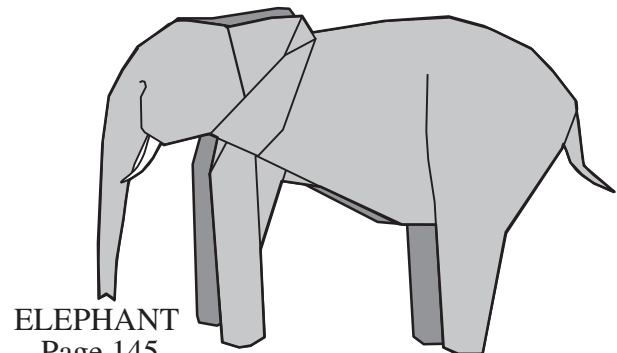

ELEPHANT
Page 145

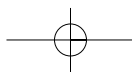

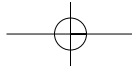

Niveau de difficulté : Complexe

Carré couleur : Recto

Format : 17 cm

Modèle terminé : 8 cm

Papier : 70 g

MARTIN-PECHEUR

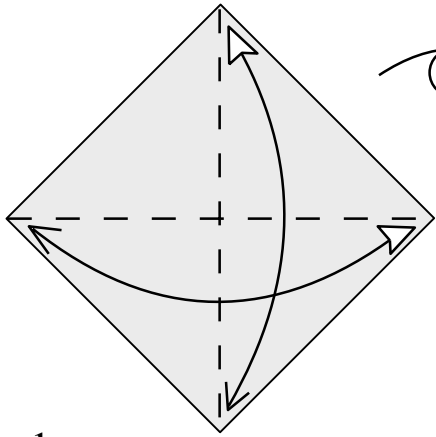

1
Plier et déplier les deux diagonales.
Retourner le carré.

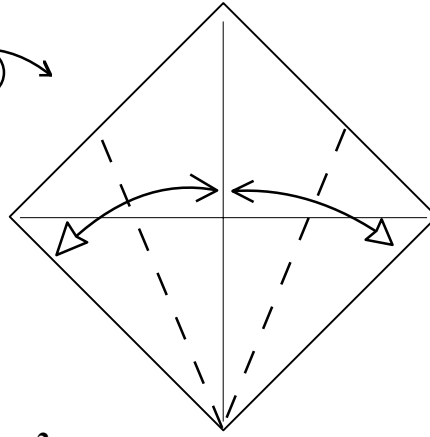

2
Plier et déplier les deux
côtés sur la diagonale.

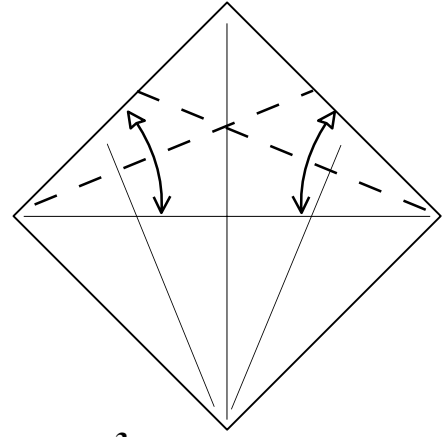

3
Plier, déplier.

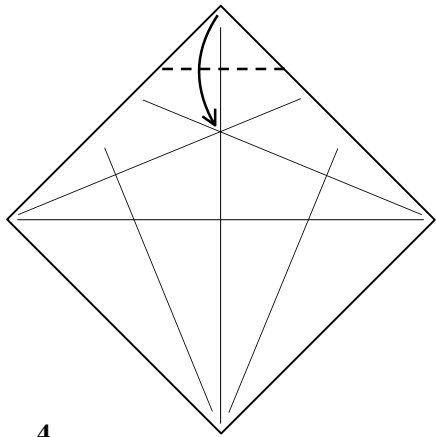

4
Plier le coin jusqu'à l'intersection des
marques des plis.

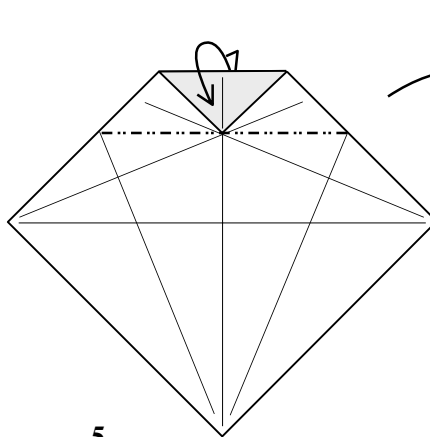

5
Plier, déplier en montagne.
Retourner le modèle.

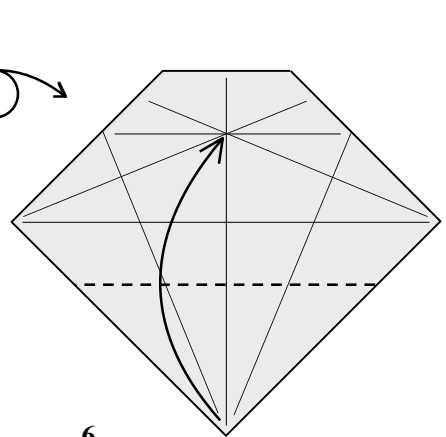

6
Plier la pointe jusqu'à
l'intersection des plis.

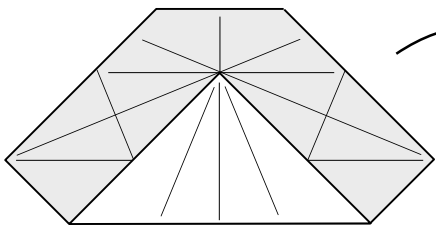

7
Retourner le modèle.

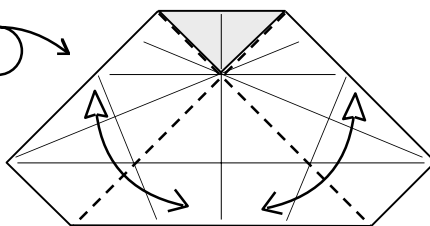

8
Plier, déplier en vallée.

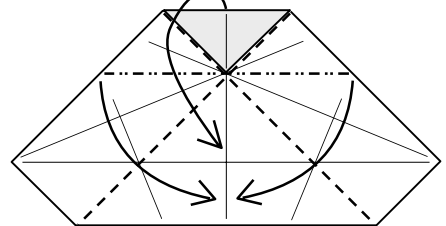

9
Plier comme pour une base
préliminaire.

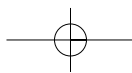

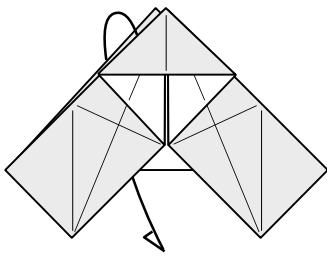
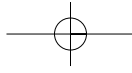

10
Plier la pointe vers le bas.

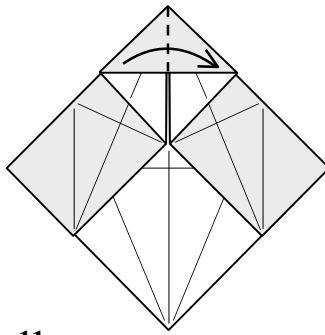

11
Plier un volet de la gauche vers la droite.

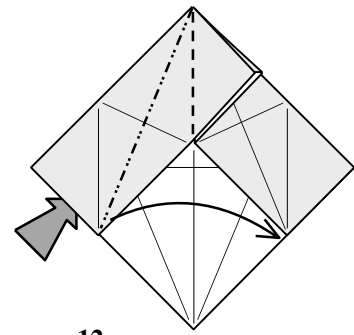

12
Pli aplati.

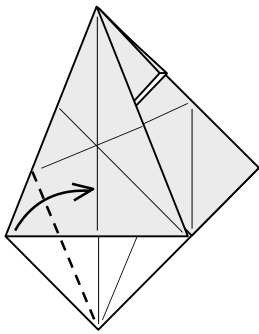

13
Pli vallée.

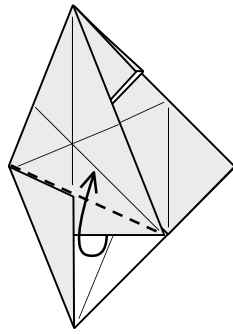

14
Libérer l'épaisseur.

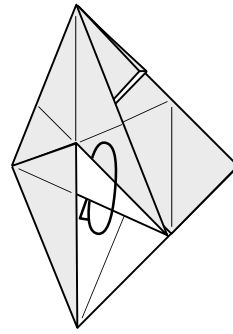

15
Plier le volet à l'intérieur.

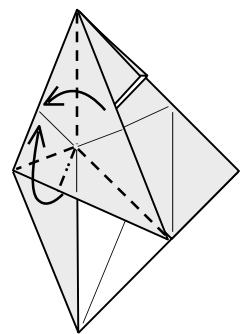

16
Pli oreille de lapin.

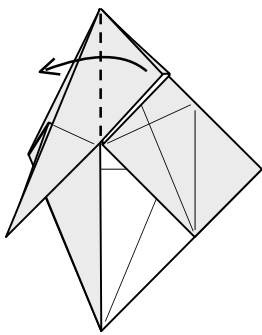

17
Plier un volet vers la gauche.

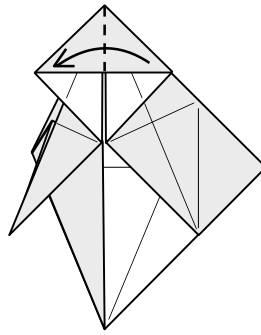

18
Répéter les opérations de 11 à 17 sur la partie droite.

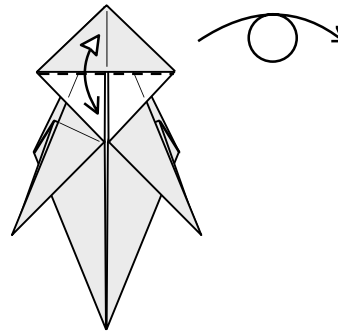

19
Plier, déplier sur toutes les épaisseurs. Retourner le modèle.

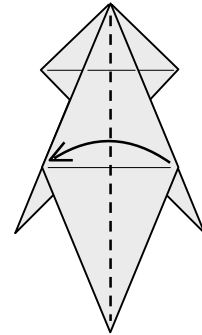

20
Plier en vallée pour fermer le modèle.

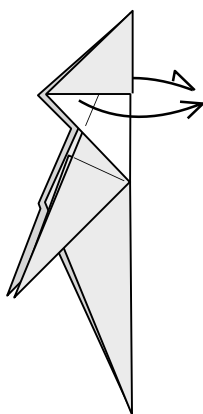

21
Plier le volet vers l'avant. Répéter derrière.

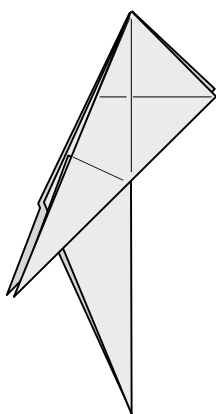

22
Rotation du modèle.

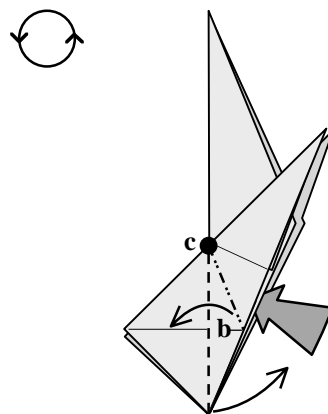

23
Pli inversé intérieur. Attention le point c est une zone sensible.

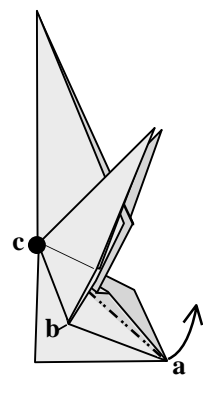

24
Vue intermédiaire du pli 23.

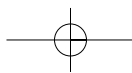

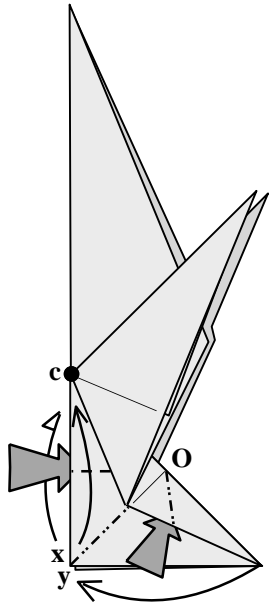
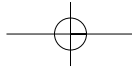

25
Plier **x** derrière et **y** devant vers **c**, en utilisant **O** comme axe de pivot.

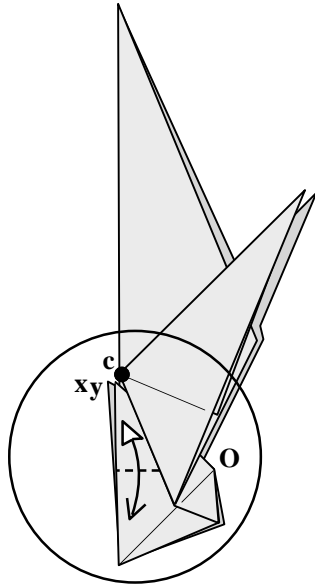

26
Plier, déplier. Répéter derrière. Sélection de la zone de travail.

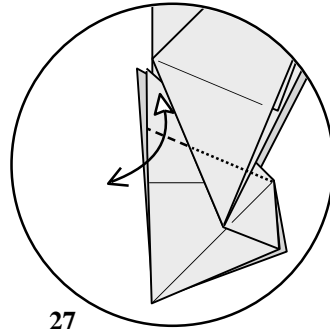

27
Plier, déplier. Répéter derrière.

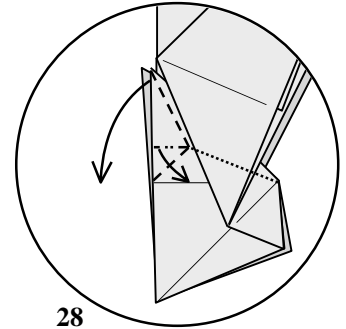

28
Pli oreille de lapin. Répéter derrière.

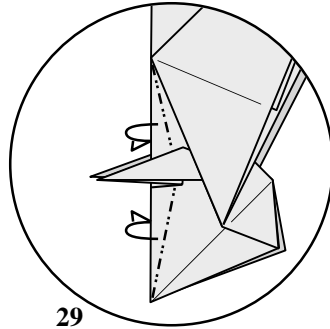

29
Plier à l'intérieur. Répéter derrière.

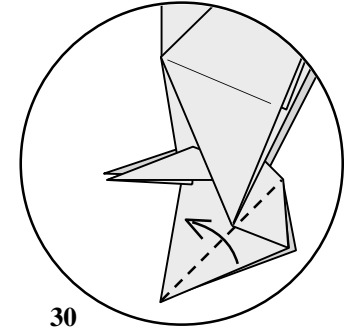

30
Pli vallée. Répéter derrière.

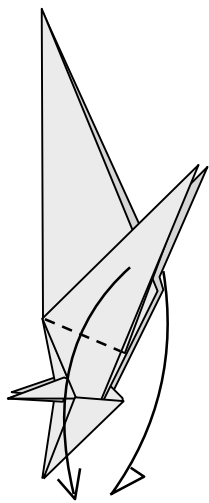

31
Plier une pointe vers le bas. Répéter derrière.

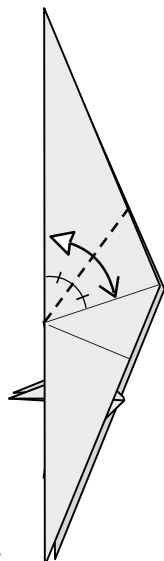

32
Plier, déplier la bissectrice.

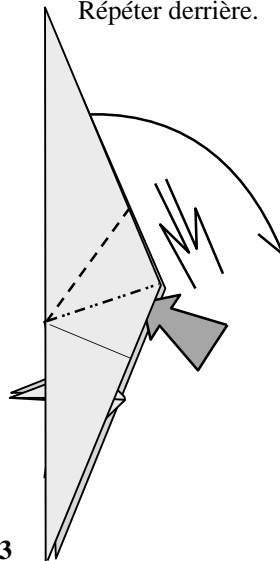

33
Repli intérieur.

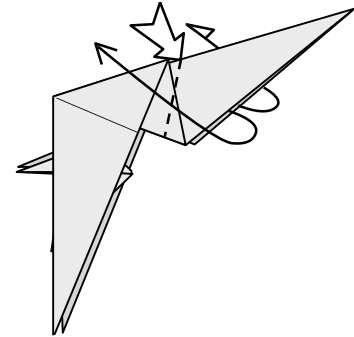

34
Pli inversé extérieur.

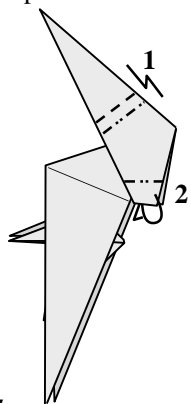

35
1 Repli pour le bec.
2 Pli inversé intérieur pour la tête. Répéter derrière.

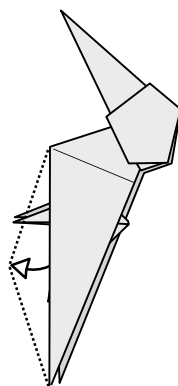

36
Dégager une épaisseur sous l'aile. Répéter derrière.

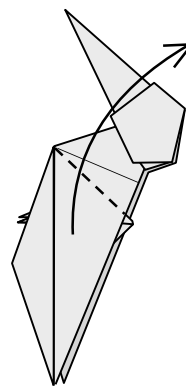

37
Remonter l'aile. Répéter derrière.

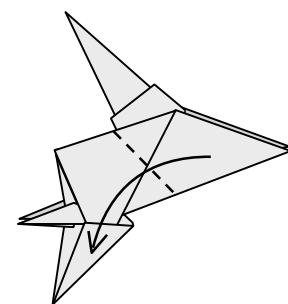

38
Plier l'aile vers le bas. Répéter derrière.

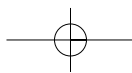

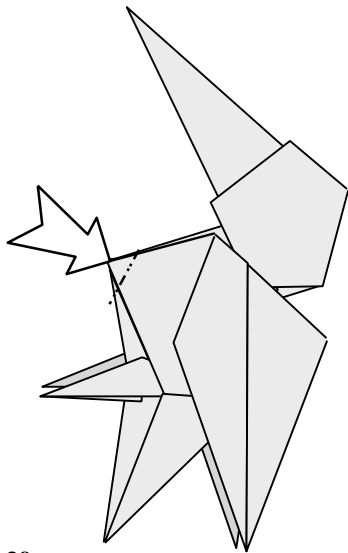
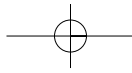

39
Enfoncement fermé
sur le ventre.
Rotation du modèle.

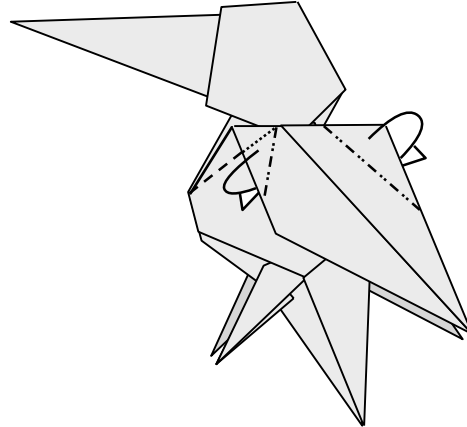

40
Former l'aile.
Répéter derrière.

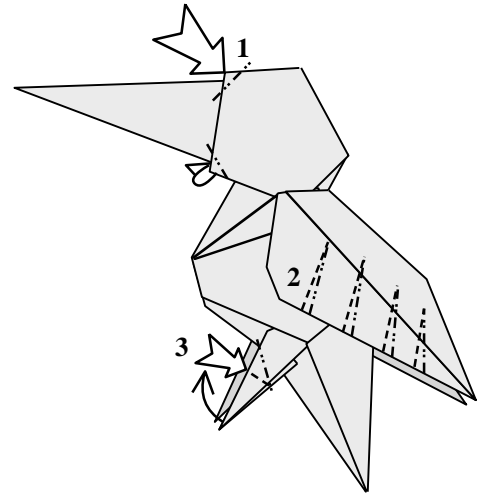

41
1 Modelage de la tête.
2 Repli pour l'aile.
3 Repli inversé pour la patte.
Répéter derrière.

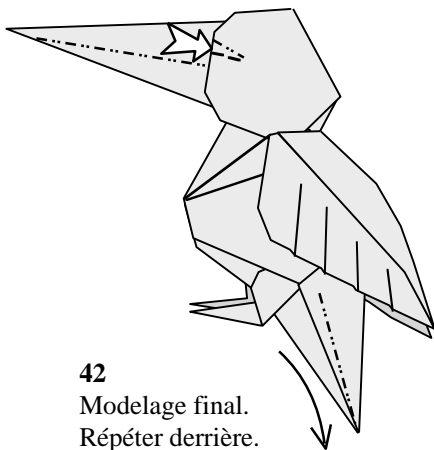

42
Modelage final.
Répéter derrière.

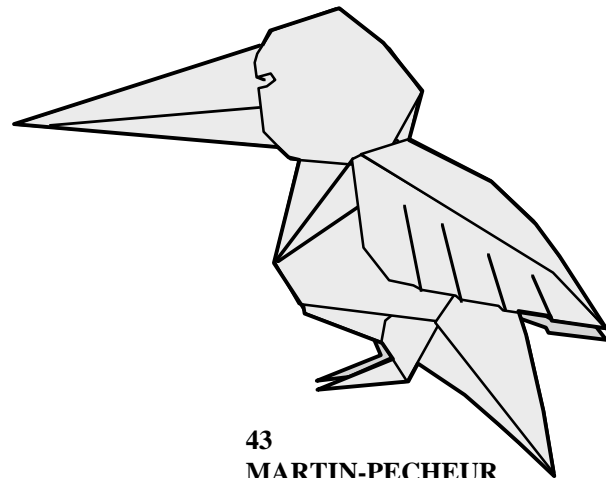

43
MARTIN-PECHEUR
TERMINE.

